

RG

Integrally geared compressors

Engineering the Future – since 1758.

MAN Diesel & Turbo



RG – Integrally Geared Compressors

High efficient multi-shaft centrifugal compressors

MAN Diesel & Turbo's integrally geared centrifugal compressors feature a multi-stage arrangement allowing up to 5 pinions. All shafts are equipped with maintenance-free tilting pad bearings. The RG compressor can contain up to ten impeller stages. This enables a very compact design, compression of a wide range of gases, and high pressure ratio.

With improved impeller design, optimized pinion speeds and tailored aerodynamics, MAN Diesel & Turbo's RG guarantees the absolute highest level of efficiency. The compressor inlet flow is typically controlled by inlet guide vanes.

To achieve minimum on-site installation times, MAN Diesel & Turbo offers a complete package option for most applications. It consists of compressor core unit, driver, process gas coolers, lube oil system, process piping and auxiliaries. For shaft sealing, carbon rings are standard, but labyrinth seals and dry gas seals can be used as well.

Modular configuration

Configuration range from fully standardized modular air booster and fuel gas compressors, to custom manufactured high pressure booster and CO₂ compressors.

Delivery times can be shortened significantly by using standardized pre-assembled component designs with proven performance and reliability track records.

Applications

- Industrial gases (Air separation, paper, etc.)
- Oil & Gas (CCS, EOR, gas transport, natural gas, etc.)
- Refinery (IGCC, Coal-to-Liquids, GTL syngas, etc.)
- Chemicals & Petrochemicals (Vapor, heat pump, propane, dehydration, methanol, etc.)
- Fertilizer industry (Ammonia, urea, nitric acid)
- Iron & Steel, mining (Blast furnace, etc.)
- Power generation (Fuel gas supply)

Base characteristics

Multistage design

- Full accordance with API
- Individual speed for each pinion (1,500 – 50,000 rpm)
- Multiple services within one unit
- Intercooling between each stage
- Direct drive shaft for steam turbine
- Max. number of impeller stages: 10
- Max. number of pinions: 5
- Open and closed impellers with welded or brazed shrouds
- Impeller sizes: from 100 to 1,600 mm

Flexible Control System

- Anti surge system for multiple stage groups
- Performance control
- Inlet guide vanes at first or at all compressor stages
- Optionally, variable speed control and suction throttling



Highly flexible due to variable impeller sizes and inlet guide vanes

Features

Impeller speed individually selectable for each pair

Modular component packages available

Modular sealing systems – several sealing options, e.g. carbon ring, single and tandem dry gas seals and labyrinth seals

Direct or pinion drive

Handles a wide range of gases: dry and atmospheric air, carbon oxide, carbon dioxide, water-vapor, natural and fuel gas, nitrogen, helium, propane, propylene (heat pump), etc.

Individual process stages can be controlled within one casing

Combined applications within one casing e. g.: air, dry air and nitrogen

Integrated interstage coolers (water) beneath compressor skid

Intercooling possible after each stage

Advanced impeller technology for higher pressures

Benefits

Optimum flow coefficient, cost and energy savings

Short delivery times, quick assembly

High degree of flexibility in applications

Maximum driver flexibility – electric motor, steam turbine or gas turbine drivers are possible

High degree of flexibility in applications

Cost and space efficient operation

Cost and space efficient operation

Compact design, small footprint, easy installation

Less external driving power required

Compression up to 250 bar

Typically RG integrally geared co

Inlet guide vanes

Impeller



Compressor with 4 stages

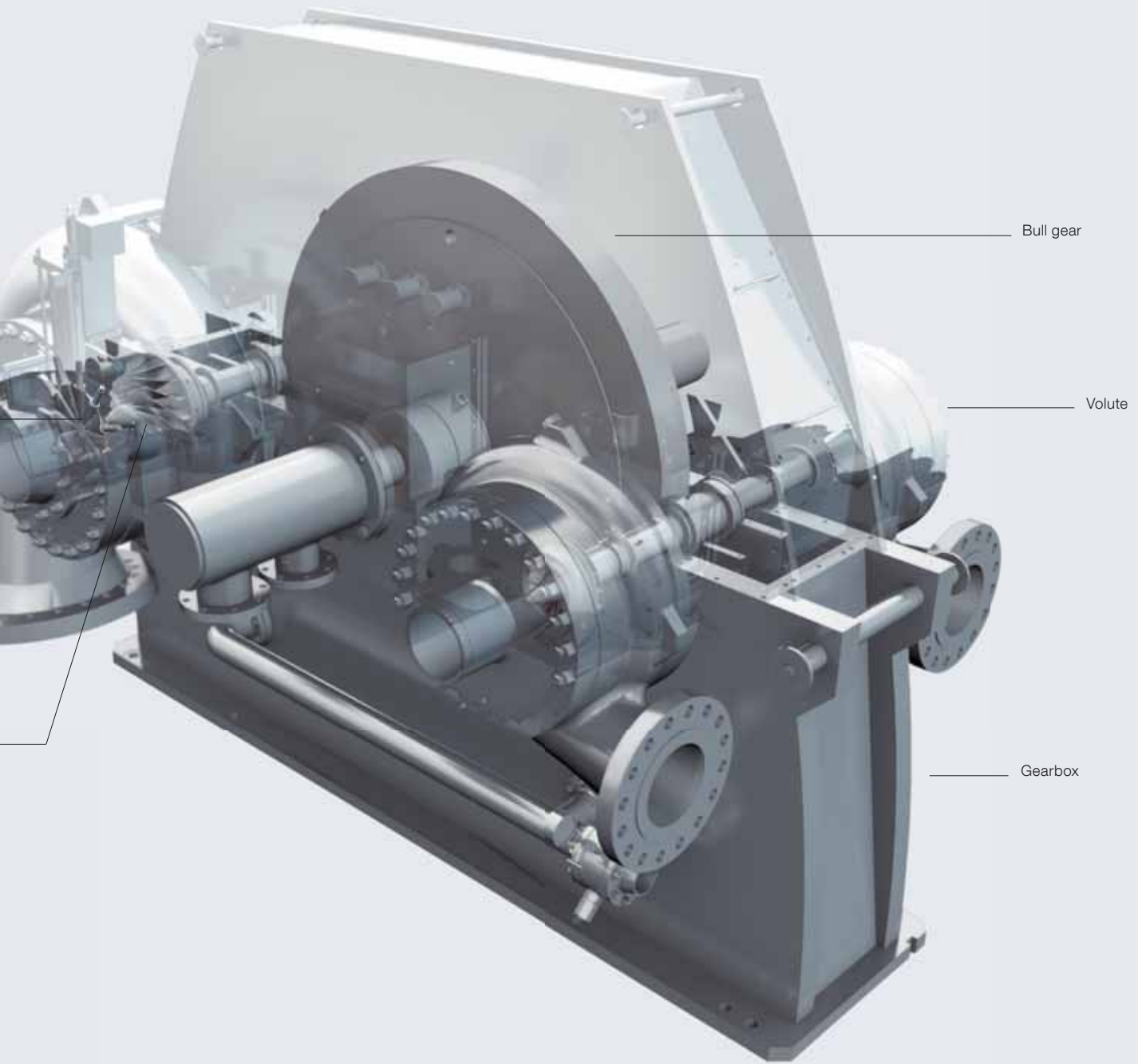

Driver	Electric motor, steam turbine or gas turbine
Min. suction pressure [bara]	0.4
Discharge pressure [bara]	Max. 250
Flow rate [m ³ /h]	Max. 550,000
Power range [MW]	Up to 60
Efficiency [%]	> 80% overall efficiency possible
Number of pinions	Up to 5
Number of impellers	Up to 10

Type*		RG25	RG40	RG45	RG50	RG56	RG80	RG100	RG140	RG160
Length	mm	2,700	3,000	3,400	3,700	4,000	4,500	5,500	-	-
Width	mm	3,600	3,600	3,600	3,600	3,600	3,600	3,600	> 3,600	> 7,000
Height	mm	2,000	2,500	3,000	3,300	3,500	4,000	5,000	7,000	> 7,000
Weight	t	15	30	40	45	50	60	> 60	> 60	> 130
Flow	Am ³ /h	10,000	25,000	30,000	40,000	50,000	100,000	200,000	350,000	550,000
Power	MW	4	15	18	20	20	20	35	50	60

* Dimensions related to core unit

Typical arrangement

RG56 Skid incl. cooler

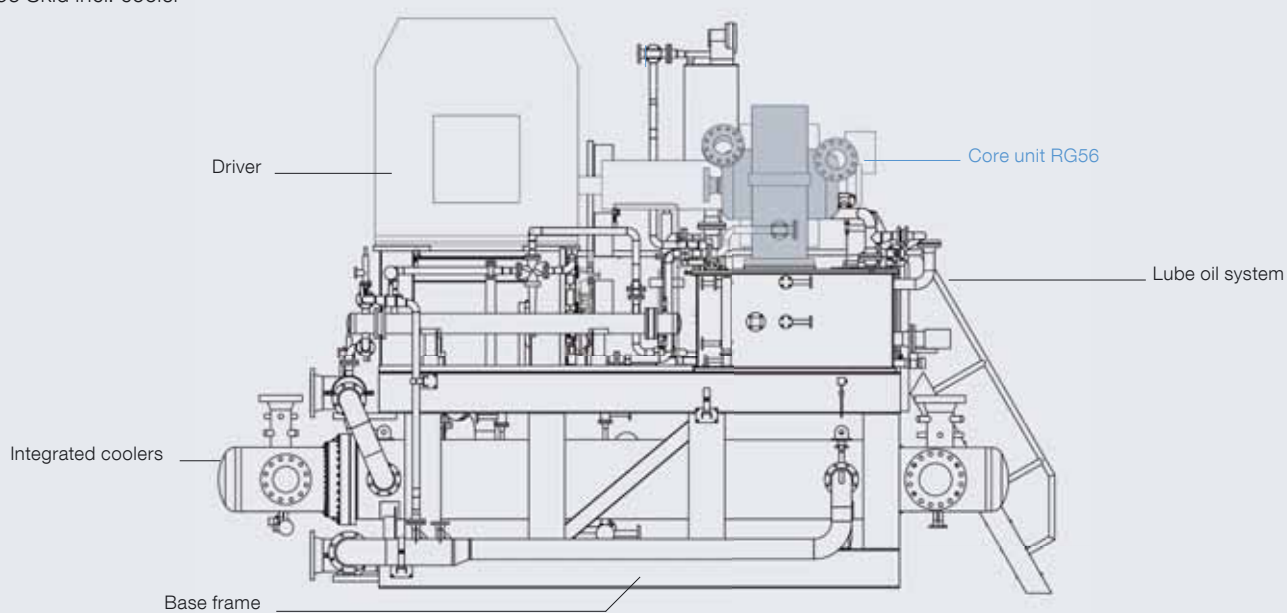

All data provided in this document is non-binding. This data serves informational purposes only and is especially not guaranteed in any way. Depending on the subsequent specific individual projects, the relevant data may be subject to changes and will be assessed and determined individually for each project. This will depend on the particular characteristics of each individual project, especially specific site and operational conditions. Copyright © MAN Diesel & Turbo. D02082015EN Printed in Germany GMC-OBH09121.5

MAN Diesel & Turbo

46145 Oberhausen, Germany

Phone +49 208 692-01

Fax +49 208 669-021

www.mandieselturbo.com

MAN Diesel & Turbo

Center of Competence for RG Compressors

Business Unit Oil & Gas

Egellsstr. 21

13507 Berlin, Germany

Phone +49 30 44042-2639